



Submersible pumps

High flow

-  Sewage water
-  Civil use
-  Industrial use



PERFORMANCE RANGE

- Flow rate up to **5000 l/min** (300 m³/h)
- Head up to **22 m**

APPLICATION LIMITS

- **10 m** maximum immersion depth (with a sufficiently long power cable)
- Maximum liquid temperature **+40 °C**
- Passage of suspended solids up to **Ø 80 mm**
- \To have continuous duty, the pump has not to emerge (to be out) of the water for more than **290 mm**

CONSTRUCTION AND SAFETY STANDARDS

- **10 m** long power cable

EN 60335-1
IEC 60335-1
CEI 61-150

EN 60034-1
IEC 60034-1
CEI 2-3



CERTIFICATIONS

Company with management system certified DNV
ISO 9001: QUALITY



INSTALLATION AND USE

MC4 series pumps, made from heavy gauge robust cast iron, resistant to abrasion and long-lasting, are fitted with a **DOUBLE-CHANNEL** impeller and are capable of pumping liquids containing short fibred suspended solids. They are ideal for pumping **sewage, waste water, water mixed with mud, groundwater and surface water** in locations such as blocks of flats, public buildings, factories, multi-storey and underground car parks, washing areas, etc.

PATENTS - TRADE MARKS - MODELS

- Registered EU Design n. 003863158-0004

OPTIONS AVAILABLE ON REQUEST

- Other voltages or 60 Hz frequency

CHARACTERISTIC CURVES AND PERFORMANCE DATA

50 Hz n= 1450 min⁻¹

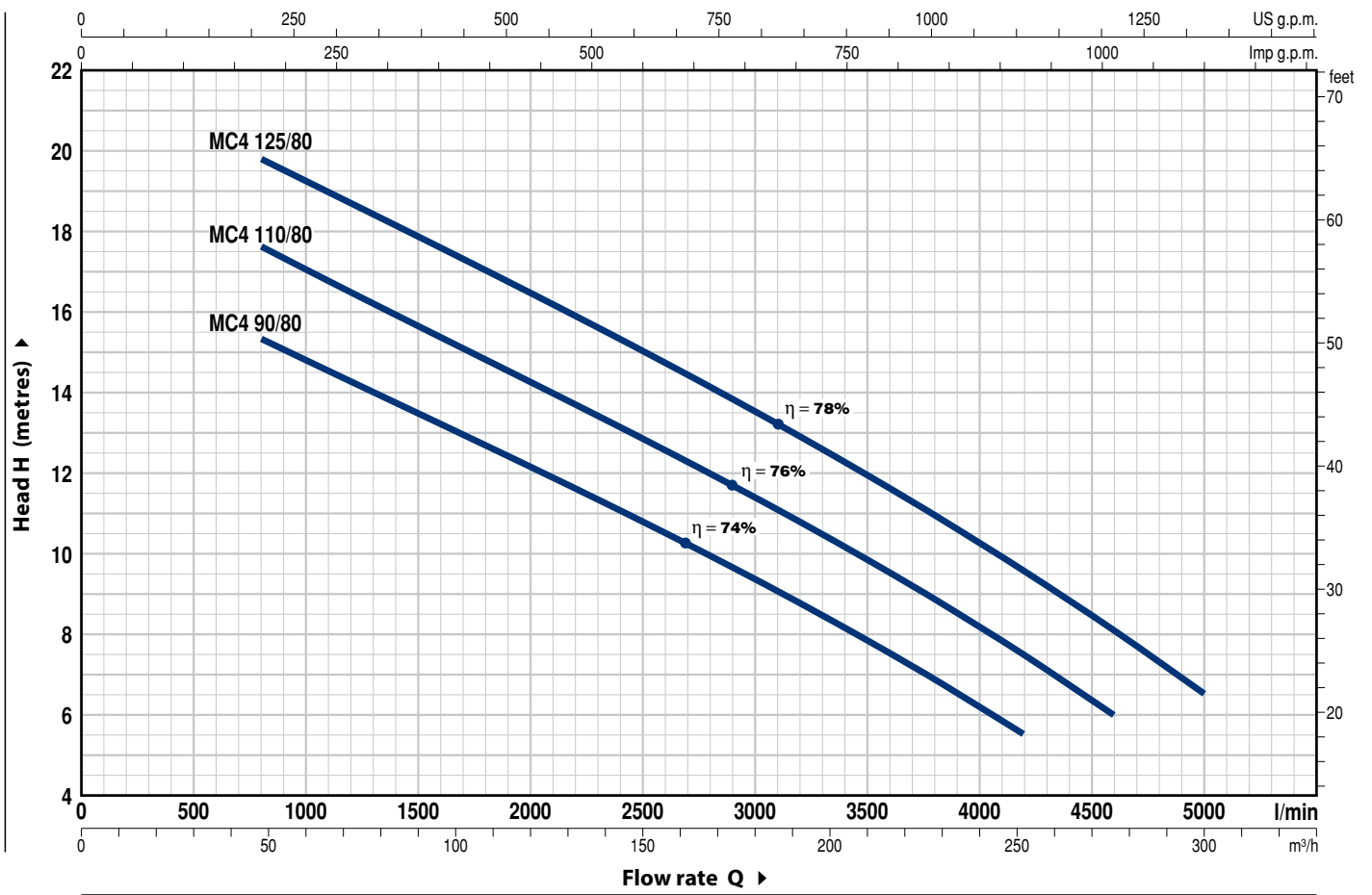

MODEL Three-phase	POWER (P ₂)		Q m ³ /h l/min	0	48	60	90	120	150	180	210	240	252	276	300
	kW	HP		0	800	1000	1500	2000	2500	3000	3500	4000	4200	4600	5000
MC4 90/80	6.7	9	H metres	17.5	15.3	14.8	13.4	12.1	10.8	9.3	7.8	6.2	5.5		
MC4 110/80	8	11		20	17.6	17	15.6	14.2	12.8	11.4	9.8	8.2	7.5	6	
MC4 125/80	9.2	12.5		22	19.8	19.2	17.8	16.4	15	13.5	11.9	10.2	9.5	8.1	6.5

Q = Flow rate H = Total manometric head

Tolerance of characteristic curves in compliance with EN ISO 9906 Grade 3B.

POS. COMPONENT CONSTRUCTION CHARACTERISTICS

1 PUMP BODY	Cast iron				
2 IMPELLER	DOUBLE-CHANNEL type in cast iron				
3 MOTOR CASING	Cast iron				
4 CASING	Cast iron				
5 MOTOR SHAFT	Stainless steel AISI 431				
6 SHAFT WITH DOUBLE MECHANICAL SEAL SEPARATED BY AN OIL CHAMBER					
<i>Seal Model</i>	<i>Shaft Diameter</i>	<i>Position</i>	<i>Stationary ring</i>	<i>Rotational ring</i>	<i>Elastomer</i>
AR-35	Ø 35 mm	Motor side	Ceramic	Graphite	NBR
MG1-40	Ø 40 mm	Pump side	Silicon carbide	Silicon carbide	NBR
7 BEARINGS	6308 2RS-C3 / 3308A 2RS-C3				
8 ELECTRIC MOTOR	<ul style="list-style-type: none"> - three-phase 400 V - 50 Hz with thermal overload protector incorporated into the winding - Insulation: class F - Protection: IP X8 				

9 PROBE DETECTING THE PRESENCE OF WATER IN THE OIL CHAMBER
10 POWER CABLE
"H07 RN-F" type
Standard length 10 metres

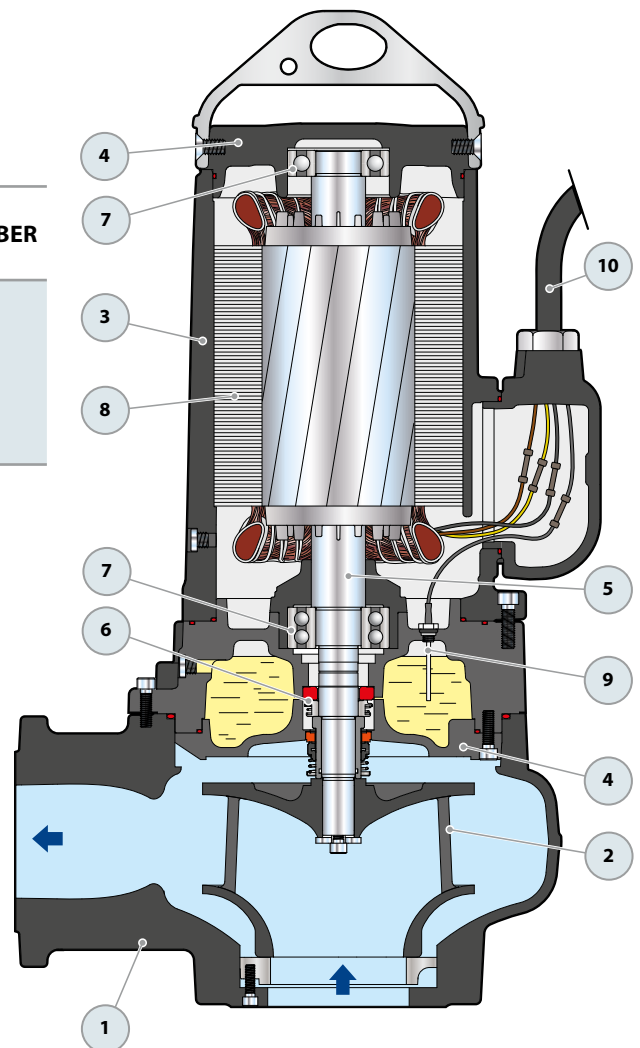

DIMENSIONS AND WEIGHT

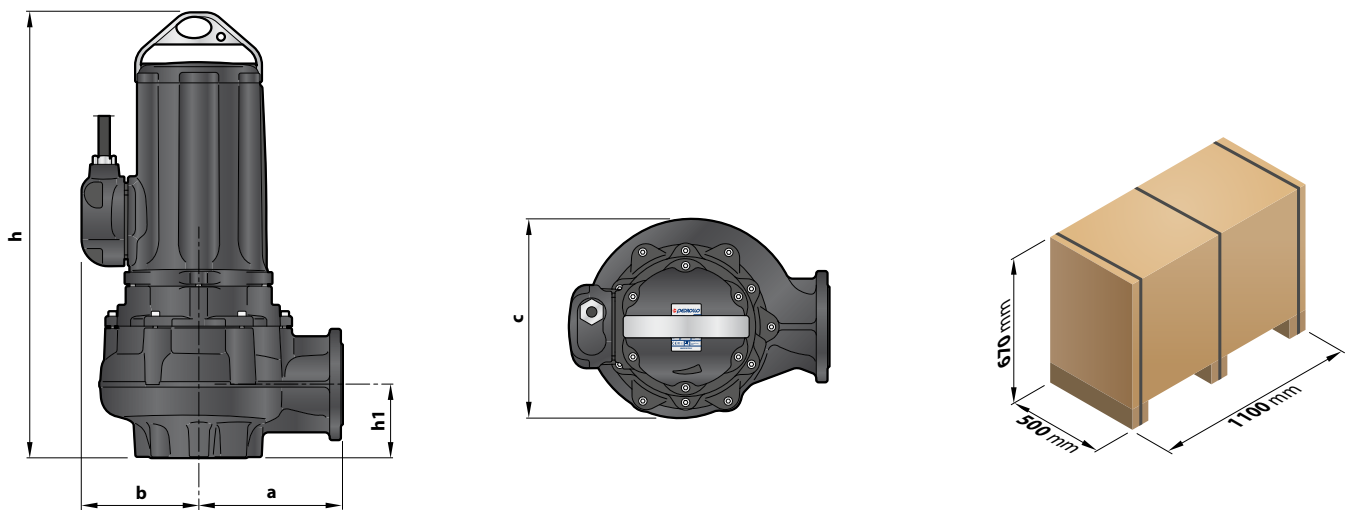

MODEL	Passage of solids	DIMENSIONS mm					kg
		a	b	c	h	h1	
Three-phase							3~
MC4 90/80	Ø 80	285	232	395	870	145	219
MC4 110/80							220
MC4 125/80							230

FLANGED PORT

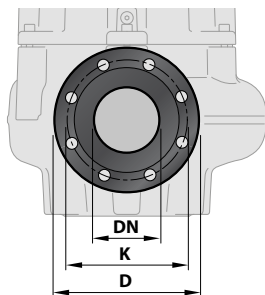

MODEL	FLANGE	K	D	HOLES	
				N°	Ø (mm)
Three-phase	DN	mm	mm		
MC4 90/80	100 (PN10)	180	220	8	18
MC4 110/80					
MC4 125/80					

COUNTERFLANGE

(TO BE ORDERED SEPARATELY)

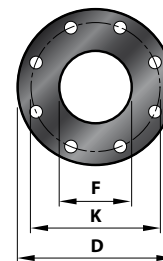

MODEL	FLANGE	F	K	D	HOLES	
					N°	Ø (mm)
Three-phase	DN		mm	mm		
MC4 90/80	100	4"	180	220	8	18
MC4 110/80						
MC4 125/80						

ABSORPTION

MODEL	VOLTAGE
Three-phase	400 V
MC4 90/80	14.5 A
MC4 110/80	17.5 A
MC4 125/80	18.5 A

BASE

(TO BE ORDERED SEPARATELY)

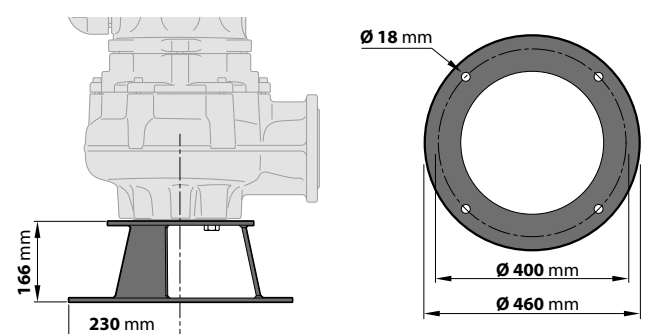

SEWAGE LIFTING SYSTEM VXC4 – MC4



VERTICAL DELIVERY VERSION WITH 2" GUIDE TUBES

For VXC4, MC4	Cod. ASSPVXC4V	DN 4"
----------------------	----------------	-------

Kit consisting of:

- footing connection complete with counterflange
- slide guide with screws and seals
- support for the guide tubes

STANDARD INSTALLATION

- | | |
|---|--|
| 1. Pump | 7. Control box |
| 2. Footing connection | 8. Stop float switch |
| 3. Guide tubes | 9. Starting float switch |
| 4. Support for the guide tubes | 10. Starting float switch auxiliary pump |
| 5. Intermediate support for the guide tubes | 11. Alarm float switch |
| 6. Lifting chain | 13. Cement base |

SLIDE GUIDE (Also to be ordered separately)

For VXC4, MC4	Cod. ASSFL100
----------------------	---------------

Complete with screws and seals

● INTERMEDIATE SUPPORT (To be ordered separately)

Cod. 859SV349INTFA	Guide tube Ø 2"
--------------------	-----------------

In order to ensure stability, insert the intermediate support every three metres of guide tube (recommended)



GUIDE TUBES (AISI 304 stainless steel)

Cod. 54SARTG006	Ø 2"
-----------------	------

Maximum length of the tube plank: 6 metres

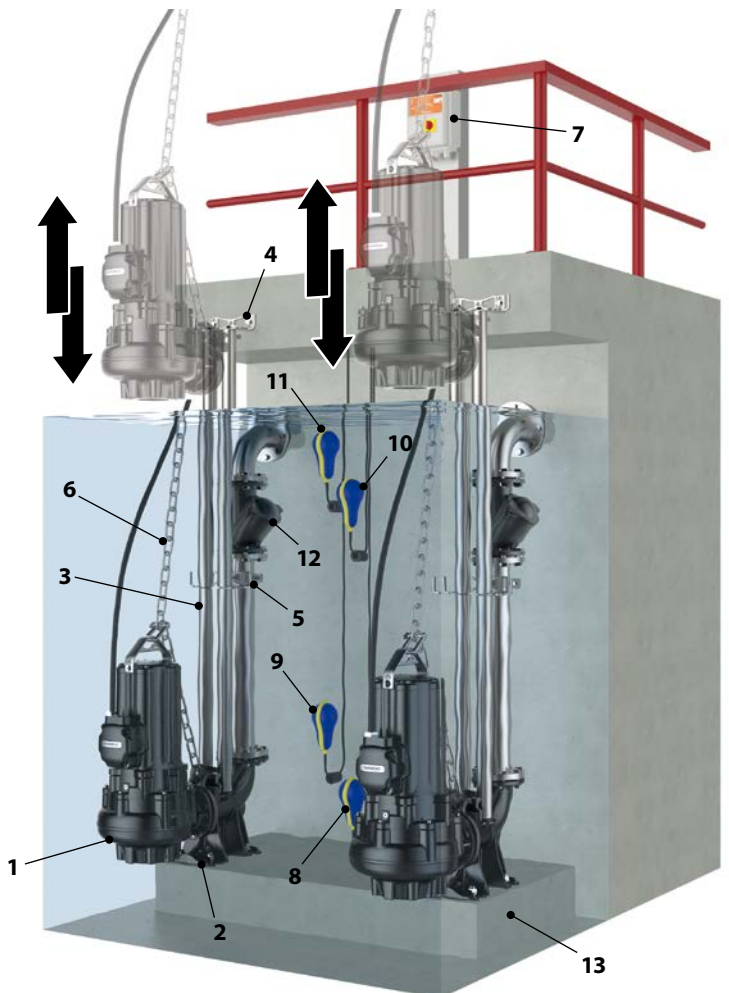

DIMENSIONS

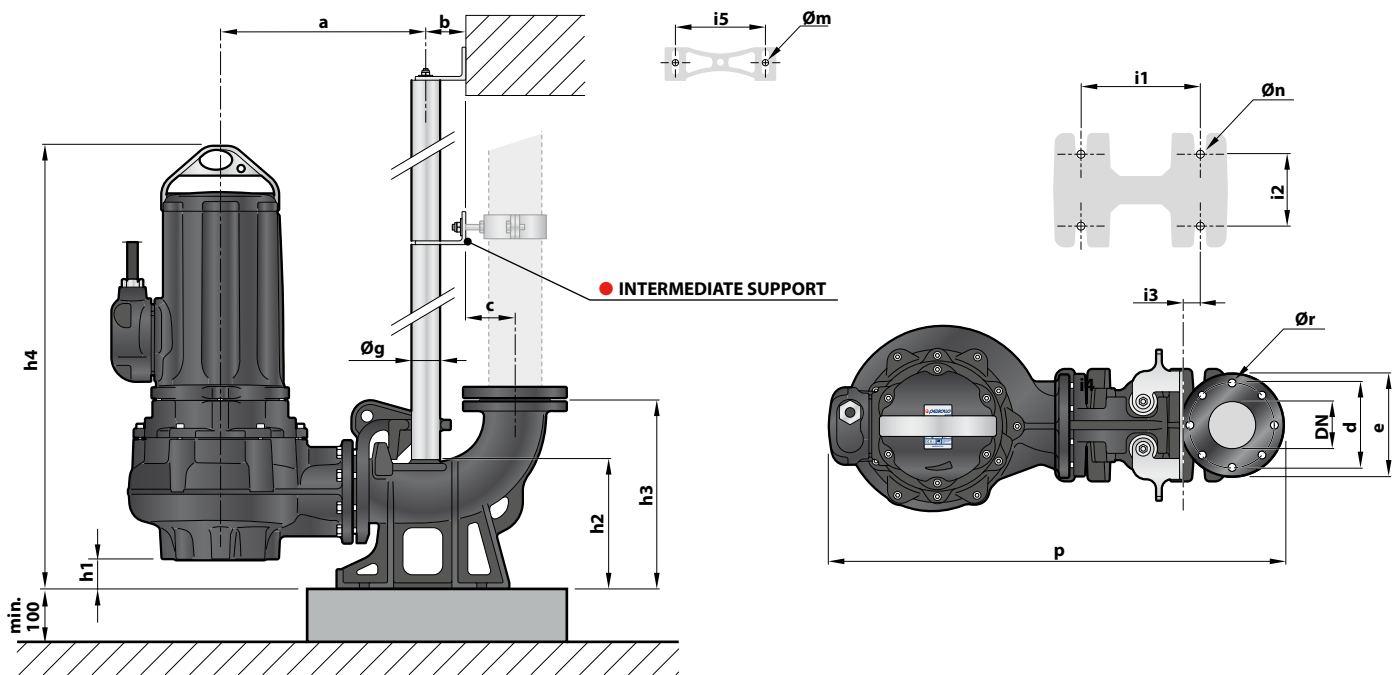

MODEL	Passage of solids mm	PORT DN	DIMENSIONS mm																	
			a	b	c	d	e	p	h1	h2	h3	h4	i1	i2	i3	i5	Øg	Øm	Øn	Ør
Three-phase																				
VXC4 /80	Ø 80	100	435	85.5	104.5	180	220	965	62	275	400	930	250	150	34	187	2"	13.5	22	18
MC4 /80																				